

TYPE	OUTPUT		POLE	TIME RATING	VOLTAGE V	Hz	SYN. SPEED R. P. M
	HP.	kW.					
AEHH-GD	450	335.7	4	CONT.	460	60	1800

TOTALLY ENCLOSED FAN-COOLED TYPE, SQUIRREL-CAGE ROTOR
 PRIMARY T-BOX (2-NPT3')

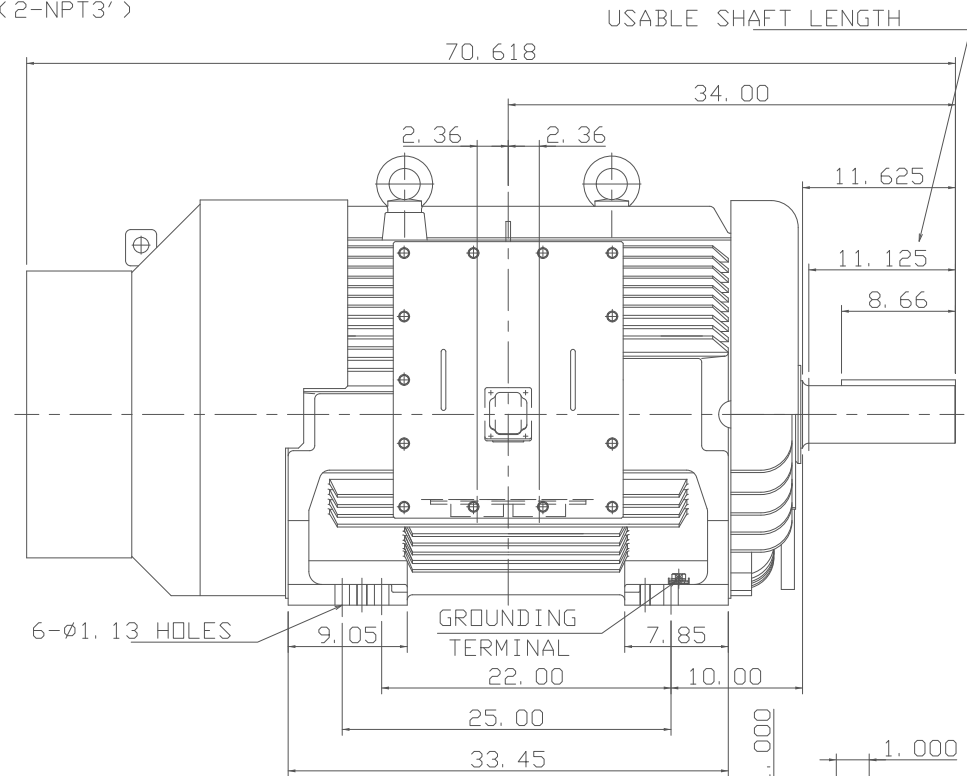
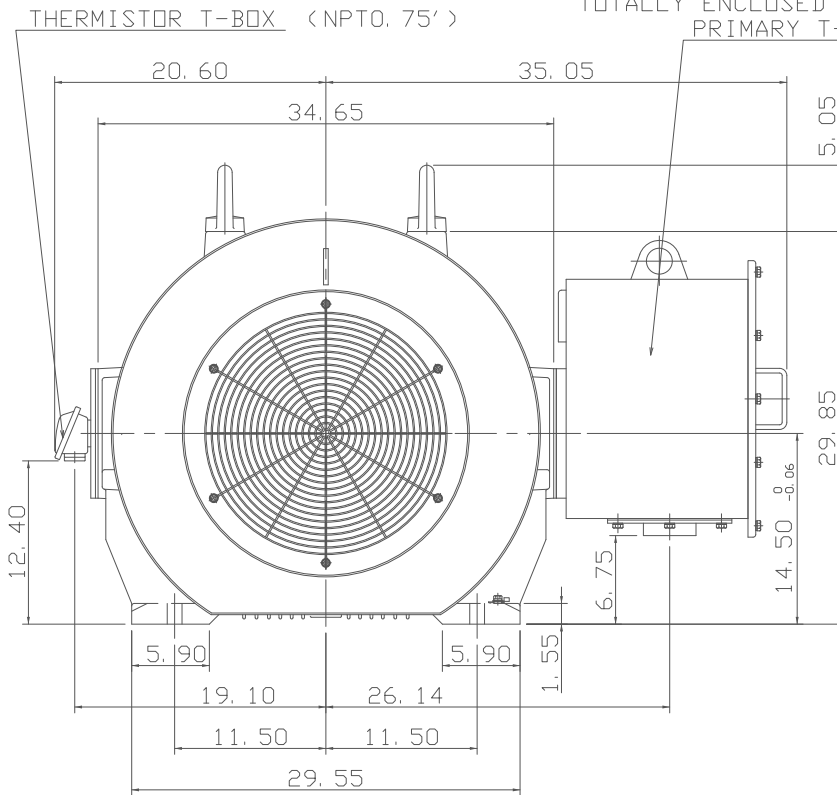

SHAFT END
(ENLARGED VIEW)

NOTE:

1. DIMENSIONS IN inch
2. FRAME NO.586/7UZ
3. F CLASS INSULATION, S. F. 1. 15
4. FOR BELT DRIVE
5. ENCLOSURE: IP55
6. BEARING SIZE: DRIVE-END NU326C3
OPP. DRIVE-END 6322
7. NON-SPARKING FAN
8. WITH THERMISTOR: PTC 140°C 3PCS
9. MOTOR APPROX. WEIGHT: 5170lb

DATE	FEB. 01, 2018		OUTLINE DIMENSIONS	
CATALOG NO.:	CDP4504RZ		3-PHASE INDUCTION MOTOR	
DWN.	J. WANG	MAR. 10. 2017	TEC Westinghouse	DWG NO.
CHKD.	H. HUANG	MAR. 10. 2017		REV: 02
APPD.	C. LIU	MAR. 10. 2017		4B040T889

6 5 4 3 2 1

6 5 4 3 2 1